

Lyman[®]



Case Trim Xpress[™]

Instruction Manual

SAVE THESE INSTRUCTIONS

ORIGINAL INSTRUCTIONS

Congratulations on your purchase of the Lyman Case Trim Xpress. Please read all instructions prior to use. Throughout the instruction manual you will find TRIMMING TIPS, these helpful tips will assist the user in set up, operation and troubleshooting the trimmer.

**Note: Designed for use with bottleneck cases only!!
Do not try to trim straight cases.**



WARNING Read all safety warnings, instructions, illustrations and specifications provided with this power tool. Failure to follow all instructions listed below may result in electric shock, fire and/or serious injury.

SAVE ALL WARNINGS AND INSTRUCTIONS FOR FUTURE REFERENCE.

- Safety precautions should always be used when operating this electrical appliance.
- Keep all loose clothing, hands and hair away from the cutter area.
- DO NOT attempt to grab or touch the cutter while the trimmer is running.
- DO NOT operate trimmer without Adjuster Barrel installed, serious injury can result.
- DO NOT change bushings with trimmer running, always turn the trimmer off and disconnect from the power source prior to changing bushings.
- Close supervision is necessary when using this product near children
- Do not contact any moving parts
- Always wear safety glasses when using this product
- Do not use outdoors
- To reduce the risk of electrical shock do not place this appliance into water or any other liquid
- Do not store or place this appliance where it can fall or be pulled into water or any other liquid
- Do not leave appliance unattended while in use
- Remove power source when this appliance is not in use
- Appliance should only be used on a non-combustible surface, keep appliance away from all combustible materials during use



To reduce the risk of injury, user must read instruction manual



Wear ear protection



Wear eye protection



Wear dust mask



Warning



Waste electrical products must not be disposed of with household waste. Please recycle where facilities exist. Check with your local authorities or retailer for recycling advice.

1) Work area safety

a) Keep work area clean and well lit.

Cluttered or dark areas invite accidents.

b) Do not operate power tools in explosive atmospheres, such as in the presence of flammable liquids, gases or dust. Power tools create sparks which may ignite the dust or fumes.

c) Keep children and bystanders away while operating a power tool.

Distractions can cause you to lose control.

2) Electrical safety

a) Power tool plugs must match the outlet. Never modify the plug in any way. Do not use any adapter plugs with earthed (grounded) power tools. Unmodified plugs and matching outlets will reduce risk of electric shock.

b) Avoid body contact with earthed or grounded surfaces, such as pipes, radiators, ranges and refrigerators. There is an increased risk of electric shock if your body is earthed or grounded.

c) Do not expose power tools to rain or wet conditions. Water entering a power tool will increase the risk of electric shock.

d) Do not abuse the cord. Never use the cord for carrying, pulling or unplugging the power tool. Keep cord away from heat, oil, sharp edges or moving parts. Damaged or entangled cords increase the risk of electric shock.

e) When operating a power tool outdoors, use an extension cord suitable for outdoor use. Use of a cord suitable for outdoor use reduces the risk of electric shock.

- f) **If operating a power tool in a damp location is unavoidable, use a ground fault circuit interrupter (GFCI) protected supply.** *Use of an GFCI reduces the risk of electric shock.*

3) Personal safety

- a) **Stay alert, watch what you are doing and use common sense when operating a power tool. Do not use a power tool while you are tired or under the influence of drugs, alcohol or medication.** *A moment of inattention while operating power tools may result in serious personal injury.*
- b) **Use personal protective equipment. Always wear eye protection.** *Protective equipment such as a dust mask, non-skid safety shoes, hard hat or hearing protection used for appropriate conditions will reduce personal injuries.*
- c) **Prevent unintentional starting. Ensure the switch is in the off-position before connecting to power source and/or battery pack, picking up or carrying the tool.** *Carrying power tools with your finger on the switch or energizing power tools that have the switch on invites accidents.*
- d) **Remove any adjusting key or wrench before turning the power tool on.** *A wrench or a key left attached to a rotating part of the power tool may result in personal injury.*
- e) **Do not overreach. Keep proper footing and balance at all times.** *This enables better control of the power tool in unexpected situations.*
- f) **Dress properly. Do not wear loose clothing or jewelry. Keep your hair and clothing away from moving parts.** *Loose clothes, jewellery or long hair can be caught in moving parts.*
- g) **If devices are provided for the connection of dust extraction and collection facilities, ensure these are connected and properly used.** *Use of dust collection can reduce dust-related hazards.*
- h) **Do not let familiarity gained from frequent use of tools allow you to become complacent and ignore tool safety principles.** *A careless action can cause severe injury within a fraction of a second.*

4) Power tool use and care

- a) **Do not force the power tool. Use the correct power tool for your application.** *The correct power tool will do the job better and safer at the rate for which it was designed.*
- b) **Do not use the power tool if the switch does not turn it on and off.** *Any power tool that cannot be controlled with the switch is dangerous and must be repaired.*
- c) **Disconnect the plug from the power source and/or remove the battery pack, if detachable, from the power tool before making any adjustments, changing accessories, or storing power tools.** *Such preventive safety measures reduce the risk of starting the power tool accidentally.*

- d) **Store idle power tools out of the reach of children and do not allow persons unfamiliar with the power tool or these instructions to operate the power tool.** *Power tools are dangerous in the hands of untrained users.*
- e) **Maintain power tools and accessories. Check for misalignment or binding of moving parts, breakage of parts and any other condition that may affect the power tool's operation. If damaged, have the power tool repaired before use.** *Many accidents are caused by poorly maintained power tools.*
- f) **Keep cutting tools sharp and clean.** *Properly maintained cutting tools with sharp cutting edges are less likely to bind and are easier to control.*
- g) **Use the power tool, accessories and tool bits etc. in accordance with these instructions, taking into account the working conditions and the work to be performed.** *Use of the power tool for operations different from those intended could result in a hazardous situation.*
- h) **Keep handles and grasping surfaces dry, clean and free from oil and grease.** *Slippery handles and grasping surfaces do not allow for safe handling and control of the tool in unexpected situations.*

5) Service

- a) **Have your power tool serviced by a qualified repair person using only identical replacement parts.** *This will ensure that the safety of the power tool is maintained.*
- b) **If the replacement of the supply cord is necessary, this has to be done by the manufacturer or his agent in order to avoid a safety hazard.**

Case Trim Xpress Specifications:

29V DC , 11W 0.38A

AC ADAPTOR

Input:100-240V~ Output:29V DC

NOISE INFORMATION

A weighted sound pressure: 71 dB (A)

A weighted sound power:82 dB (A)

KpA&KwA: 3,0 dB (A)

Wear ear protection when sound pressure is over: 80dB (A)

VIBRATION INFORMATION

Vibration total values (triax vector sum) determined according to EN 62841-1:

Typical weighted vibration Vibration emission value ah <2,5 m/s²

Uncertainty K = 1,5 m/s²

SECTION 1

UNPACKING AND SETUP

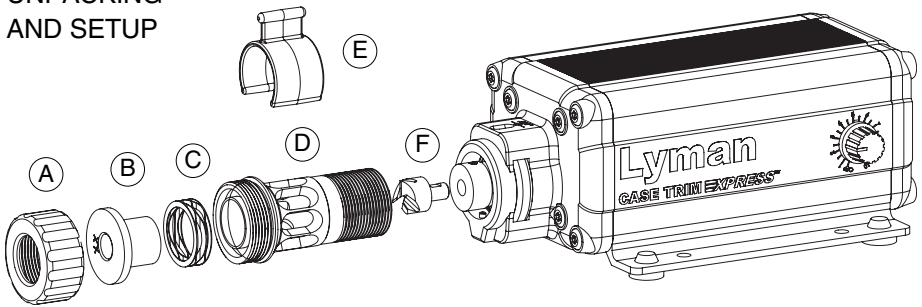

Replacement Parts

- A. Cap (Part #7810240)
- B. Bushing (See Chart on back)
- C. Spring (Part #7810241)
- D. Adjuster Barrel (Part #7810242)
- E. Chip Guard (Part #7810243)
- F. Carbide Cutter (Part #7810244)

(Not Shown)

- (#7810245) 29V DC Power Supply
- (#7994460) EU Cordset 230V
- (#7994461) UK Cordset 230V
- (#7994462) SA Cordset 230V
- (#7994463) AUS Cordset 230V
- (#7994464) US Cordset 115V

1. Remove the trimmer and all accessories from packaging, ensure all parts are present. Included in the box will be;

a. Power supply. Note: the 115 volt model will include one power cord. The 230 volt model will include four different power cords.

b. Trimmer unit with Bushing Cap, Adjuster Barrel, Spring, Cutter Head and a Chip Guard. (See Diagram above.)

c. 10 bushings.

2. Minimal assembly is required. Plug power cord into back of trimmer and power outlet. (pic 1)

3. Turn power knob to the on position, ensuring that motor powers on and spins freely. (pic 2)

4. Remove power cord from trimmer for next step. **Remember to ALWAYS remove power cord prior to changing bushings or replacing cutter head.**



SECTION 2

Setting Trim Length

The Case Trim Xpress is supplied with 10 different bushings covering a wide range of popular bottleneck cases. Additional bushings can be purchased for calibers that are not covered by the supplied bushings. Please refer to the bushing chart on back for caliber information and part numbers.



1. Select the proper bushing for the caliber you are trimming. Unthread the bushing cap (pic 3). Under the bushing cap you will find a compression spring, this spring must be installed in order for the trimmer to function correctly.



2. Place the bushing into the adjuster barrel as shown (pic 4) with the bushing number facing you. Reinstall the bushing cap and tighten.

3. Locate the Cutting Depth Adjustment wheel (pic 5). Each white graduation mark represents .001" increments. Turning the adjustment wheel clockwise will DECREASE your cutting depth (less material removed). Turning the adjustment counter-clockwise will INCREASE your cutting depth (more material removed).



A viewing window is located at the top of the adjustment wheel housing, this window will allow the user to view the graduation marks to ensure a proper setting.

4. Measure a case to be trimmed, making note of the untrimmed length. (pic 6) **TRIMMING TIP:** Because the bushing uses the shoulder of the case to determine trim length, all cases should be cleaned and sized before trimming to ensure an accurate and consistent result. If your cases have been sized at



different times there is a chance your size die setting could vary thus giving the user inconsistent results.

5. Insert the case to be trimmed. Push the case and bushing against the compression spring with even pressure until the case bottoms out. (pic 7) Observe the distance from the case mouth to the cutter head. (pic 8) If the case mouth IS contacting the cutter head, turn the adjustment wheel clockwise until the cutter is barely contacting the case mouth. If the case mouth IS NOT contacting the cutter turn the adjustment wheel counter-clockwise until the cutter barely touches the case mouth.



TRIMMING TIP: when setting the initial cutting depth make sure you have fully compressed the spring; repeat this step a few times, to ensure the proper initial setting.

6. Once you have your initial setting turn your adjustment wheel counter-clockwise one graduation mark. Turn trimmer to the highest RPM setting and compress the case into the bushing with even pressure and trim. TRIMMING TIP: Using even pressure each time you trim a case will help the user achieve clean and consistent trim lengths each time.
7. Remove the case and measure your case again, compare that with the start length of the case that you made note of earlier. Your case should be at least .001" shorter.

TRIMMING TIP: Always trim at the highest RPM setting. If you observe chatter on the case mouth, slowly adjust RPM down until chatter is gone.

8. Once you have measured the case, you can now set the adjustment wheel the correct number of graduation marks in order to achieve your correct trim length.

TRIMMING TIP: Here is an example of steps 5,6,7,8: .270 Win case with untrimmed length of 2.546". Initial setting completed, adjustment wheel is turned one graduation mark, then trim a case. Trimmed case measures 2.545". Turn adjustment wheel counter-clockwise 15 graduation marks (trim to length for .270 Win is 2.530"). Trim case and measure. Your case should now measure 2.530". Your trimmer is now set to trim your .270 Win cases to the correct trim to length of 2.530". With some practice and using firm

even pressure each time you trim a case, you should be able to achieve clean consistent trim-to lengths.

SECTION 3

Operating Instructions

1. The Case Trim Xpress can be mounted to your reloading bench. There are 4 mounting holes that can be used to directly mount the trimmer. The trimmer can also be used unmounted and hand held against the bench. The trimmer is equipped with non-slip rubber feet that will help prevent the trimmer from sliding when in use.

TRIMMING TIP: You can use your hand to hold the rear of the unit as you are trimming for added stability.

2. Verify that you have set your trim length, as described in Section 2.

3. Prior to operating your trimmer, the Chip Guard should be installed. With the Chip Guard installed, it will allow the brass chips to collect in one area keeping your bench clean.

To install the Chip Guard, place on top of the Adjuster Barrel as shown and snap into place. (pic 9)



4. Turn your trimmer on to the highest RPM setting. Insert a sized case into the Bushing. Using light, even pressure move the case forward towards the cutter. When the case makes contact with the cutter, use firm pressure but do not “JAM” the case into the cutter. This will cause rough, inconsistent cuts, which could damage the case or cutter head.

TRIMMING TIP: Turn the case 180 degrees, and trim again to insure a clean square cut.

5. Remove the case from the trimmer and measure your case again to ensure proper trim length. It is recommended that you use an inside and an outside chamfer tool to remove any roughness on the case mouth.

SECTION 4

Care and Maintenance

1. Periodically remove the Adjuster Barrel and clean any brass shavings from cutter head and shaft assembly.
2. Clean the Adjuster Barrel of any brass shavings. Remove the Bushing Cap and clean the threads on the Bushing Cap and Adjuster Barrel.
3. Inspect and clean compression spring. Inspect and clean Bushings if necessary.
4. Main body of trimmer can be wiped with a damp clean cloth if needed.

5. The Case Trim Xpress is provided with a lifetime carbide cutter head, under normal use the cutter will give the user years of clean, consistent cuts. In the event the cutter head becomes damaged, it can be changed easily.



6. To remove the cutter head, first turn the Adjustment Wheel clockwise until the Adjuster Barrel is free of the main body. (pic 10)



7. Locate the set screw on the brass cutter housing. (pic 11) Loosen set screw, and remove cutter. Use caution when working in the cutter head area, the carbide cutter is very sharp and can cause injury.



8. To install a new cutter head, first locate the "flat" on shank of the cutter head. (pic 12) The "flat" should be inserted so that the set screw will contact it when tightened. Tighten set screw firmly.

9. Reinstall Adjuster Barrel by turning the Adjustment Wheel counter clockwise. Make sure that the Adjuster Barrel is lined up correctly in main body. You will notice a slot cut on the bottom of the Adjuster Barrel, (pic 13) this needs to be aligned with the pin at the bottom of the main housing.



A light coat of oil can be applied to the Adjuster Barrel threads and Bushing Cap.

10. If the Case Trim Xpress is stored in a humid environment or for a length of time you can add a light coat of oil to the Adjuster Barrel and cutter head to prevent corrosion.

The internals of the Case Trim Xpress do not require any maintenance, therefore the housing should not be opened for any reason. Opening the housing may cause damage to the unit, and will void your warranty. If the Case Trim Xpress requires repair please contact Lyman Products Customer Service at 1-800-225-9626 to set up a return for service.

Recommendation for the operator to wear hearing protection.

_ that the declared vibration total value(s) and the declared noise emission value(s) have been measured in accordance with a standard test method and may be used for comparing one tool with another;

_ that the declared vibration total value(s) and the declared noise emission value(s) may also be used in a preliminary assessment of exposure.

_ that the vibration and noise emissions during actual use of the power tool can differ from the declared values depending on the ways in which the tool is used especially what kind of workpiece is processed; and

_ of the need to identify safety measures to protect the operator that are based on an estimation of exposure in the actual conditions of use (taking account of all parts of the operating cycle such as the times when the tool is switched off and when it is running idle in addition to the trigger time).

Recommendation that the tool always be supplied via a residual current device having a rated residual current of 30 mA or less.

Lyman®**Bushings Available For Case Trim Xpress**

Orange Blocks indicate Bushings included with Trimmer

#2 (Part #7821702) 218 Bee			#3 (Part #7821703) .223 Rem .222 Rem .17 Rem .222 Rem Mag .204 Ruger 5.56 x 45 .221 Fireball	#4 (Part #7821704) 300 AAC 17 Rem Fireball	#1 (Part #7821701) 17 Hornet 22 Hornet
#6 (Part #7821706) 220 Swift			#7 (Part #7821707) 303 British 7.62 x 39 30-40 Krag 6.5 Grendel	#8 (Part #7821708) 22-250 Rem 250 Savage 35 Remington	#5 (Part #7821705) 30 30 Win 6.8 Rem SPC 22 Nosler 224 Nosler 224 Valkyrie
#10 (Part #7821710) 30/06 .280 Rem 25/06 35 Whelen 270 Win 6.5 Swedish			#11 (Part #7821711) 9.3 x 74r	#12 (Part #7821712) .308 Win 300 Savage 243 Win 9.3 x 62 .260 Rem 6x47 Lapua 7mm/08 6 XC 338 Federal 6.5x47 Lap. 358 Win	#9 (Part #7821709) 6mm Rem 7mm Mauser 8mm Mauser 257 Roberts
#14 (Part #7821714) 375 H&H Mag			#15 (Part #7821715) 7.62 x 54R	#16 (Part #7821716) .284 Win 6.5 x 284 6 x 284	#13 (Part #7821713) 6.5mm Creedmoor 6mm Creedmoor 6mm BR Norma .22 BR 6mm Dasher
#18 (Part #7821718) .300 Win Mag .264 Win Mag 7mm Rem Mag 7mm STW .308 Norma Mag .338 Win Mag			#19 (Part #7821719) 300 RCM 338 RCM 375 Ruger	#20 (Part #7821720) .338 Ultramag 7mm Ultramag .300 Ultramag .338 Edge 375 RUM	#17 (Part #7821717) 416 Rem Mag 8mm Rem Mag
#22 (Part #7821722) 7mm Rem SAUM .300 Rem SAUM			#23 (Part #7821723) .300 WSM .325 WSM .270 WSM 7mm WSM	#24 (Part #7821724) 338 Lapua	#21 (Part #7821721) 30 Nosler 28 Nosler 27 Nosler 26 Nosler
				#25 (Part #7821725) 416 Rigby	

CE

Benn Langlais, Quality Assurance Manager

Lyman®475 Smith Street
Middletown, CT 064571-860-632-2020
www.lymanproducts.com

Rev. 03/19